

HIGH PEAK BOROUGH COUNCIL

Report to Glossop Vision Board

23 October 2012

TITLE:	Glossopdale THI – 3 Victoria St Grant application
EXECUTIVE MEMBER REGENERATION:	Councillor G Claff
OFFICER:	Dai Larner, Executive Director
WARDS INVOLVED:	Howard Town, Glossop

Appendices:

Appendix 1 – Existing photographs and proposed detailed shop front drawings

Appendix 2 – Grants budget breakdown

1. Reason for the Report:

1.2 For the Glossop Vision Board to consider a grant application at 3 Victoria Street (Pizza 4 You) towards the repair and restoration of this building.

2. Recommendation

2.1 That the Vision Board is recommended to:

2.1.1. Approve a grant of up to £79,297 towards the cost of eligible works totalling £123,477 (64%)

3. Executive Summary

3.1 Within the Glossopdale THI there has been a long desire to see the improvement of historic properties along Victoria Street. As a result of this, the THI contributed towards the architect's fees of preparing a detailed scheme of restoration works to all 7 properties. Despite an

initial positive response from property owners only two grant applications have come forward.

3.2 This report details the cost of the work and the level of grant proposed for this particular property.

4. **How this report links to Corporate Priorities**

4.1 This report concerns publicly funding the restoration and repair of traditional shop fronts within Glossop's historic town centre. This, in turn, is related to two of the Council's corporate aims:

- Supporting economic development and regeneration which incorporates the objective of high quality development control
- Protecting and improving the environment which includes the objective of promoting environmentally sustainable policies and practices. The conservation of historic buildings is inherently sustainable.

5. **Options and Analysis**

Scope of Works:

5.1 The scope of works allows for the complete repair and restoration of No 3 Victoria Street as set out in the Appendix 1. In summary this includes for the following work:

- Reinstatement of timber traditional shop front based upon photographic evidence.
- Restoration of traditional joinery details at first and second floor openings.
- Stonework repairs to front elevation (inc decorative stone parapet at roof level).
- Repairs to welsh blue slate roof and reinstatement of new cast iron rainwater goods.
- Preliminaries/contingencies
- Structural reports and asbestos survey
- Professional fees and site supervision.

Summary of Costs and Quotations:

5.2 The above scope of works is eligible for grant aid at a rate of 75% with the exception of roof and rainwater goods at 25%.

5.3 The architects originally approached 8 contractors to price the work. Only 5 tenders were returned. A breakdown of the 3 lowest tenders is submitted below:

	Quote 1	Quote 2	Quote 3
Repair and restoration of building inc shop front	90,889	104,033	105,875
Professional fees , surveys etc	12,009	12,009	12,009
Total (all exc vat)	102,898	116,042	117,884

5.4 The architects approached companies that they knew had done similar works before and had a good level of experience on working on historic buildings. The lowest estimate is provided by a company that has done work on historic properties before but their experience is perhaps somewhat limited when compared to the others.

Grant Award:

5.5 Based upon the above figures the grant would equate to the following :

	Total eligible	Grant
Repair and restoration of the building (inc shop front, stonework and traditional joinery details to upper floors @ 75%	68,704	51,528
Repair to roof and rainwater goods @ 25%	22,185	5,546
Professional fees/surveys etc @75%	12,009	9,007
Total (inc VAT)	102,898 (VAT 20,579)	66,081(VAT 13,216)

Previous Grant Applications:

5.6 The property owners have not previously received grant aid towards this property before.

6. Implications

6.1 Community Safety - (Crime and Disorder Act 1998)

No implications arising from the recommendations of the report

6.2 Workforce

No implications arising from the recommendations of the report

6.3 Equality and Diversity/Equality Impact Assessment

This report has been prepared in accordance with the Council's Diversity and Equality Policies.

6.4 Financial Considerations

There is sufficient funding available to meet this grant award and the balance of funds is shown in the financial breakdown in Appendix 2.

6.5 Legal

Local authorities are empowered to give grants towards improvements in conservation areas under Section 57 of the Planning (Listed buildings and Conservation Areas) Act 1990.

6.6 Sustainability

The sustainable reuse of buildings is intrinsically linked to the designation and positive management of conservation areas..

6.7 Internal and External Consultation

No implications arising from the recommendations of the report

6.8 Risk Assessment

No implications arising from the recommendations of the report

7. Background and Detail

- 7.1 Within the Glossopdale THI the properties along Victoria Street have been a priority target for grant aid. They stand at a crucial and focal point within the town centre and their current condition and appearance has caused much local concern. Given the importance of this row the THI funded a detail scheme of research and restoration for the buildings. As a result of this work two units have come forward for grant assistance. Whilst this is disappointing, the restoration of two units may act as a catalyst for adjacent properties to undertake such work in the future and subject to potential grant assistance.

Dai Lerner
Executive Director

**Web Links and
Background Papers**
Glossopdale THI

Location
Files held electronically

Contact details
Joanne Brooks ext 3654

APPENDIX 1

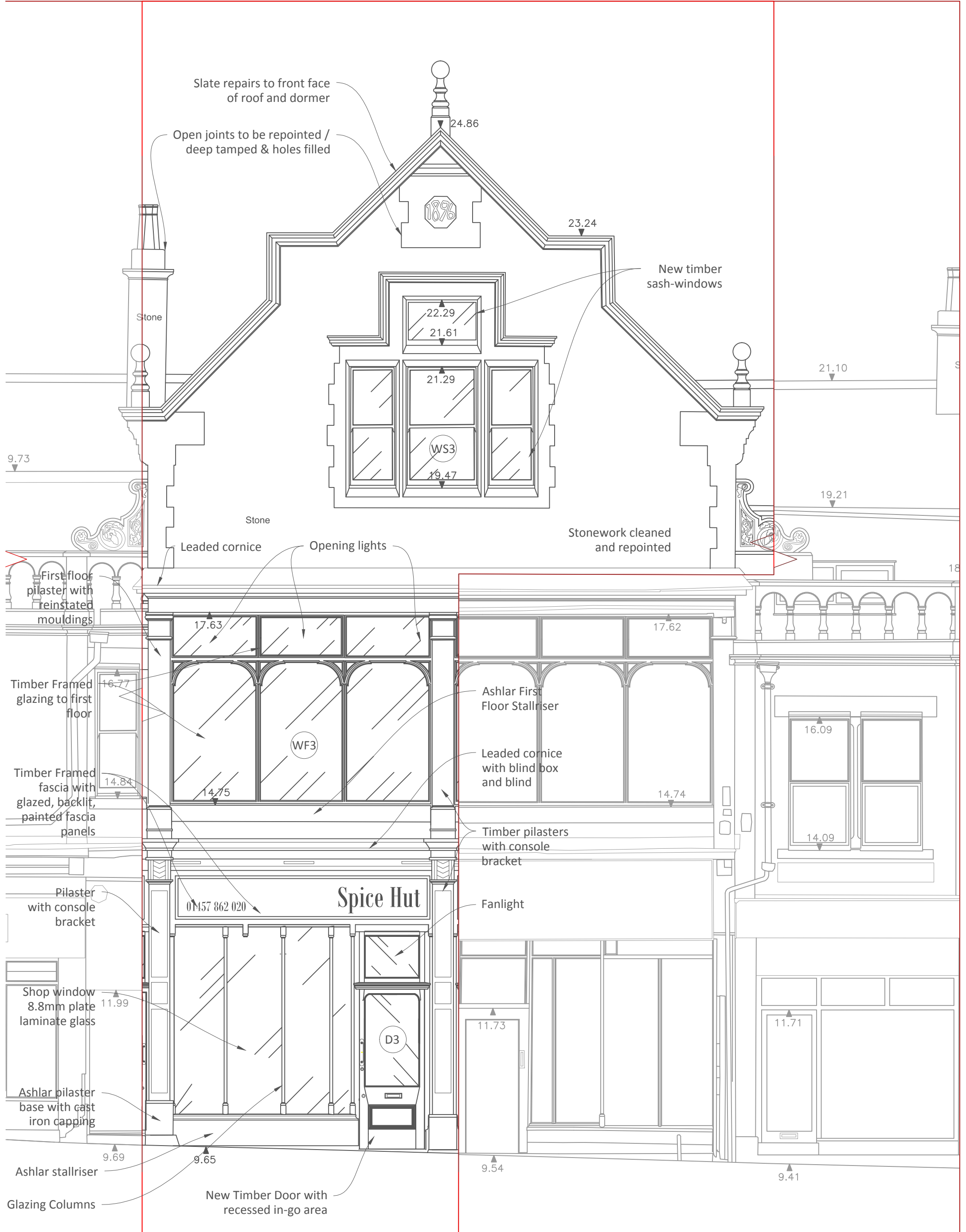





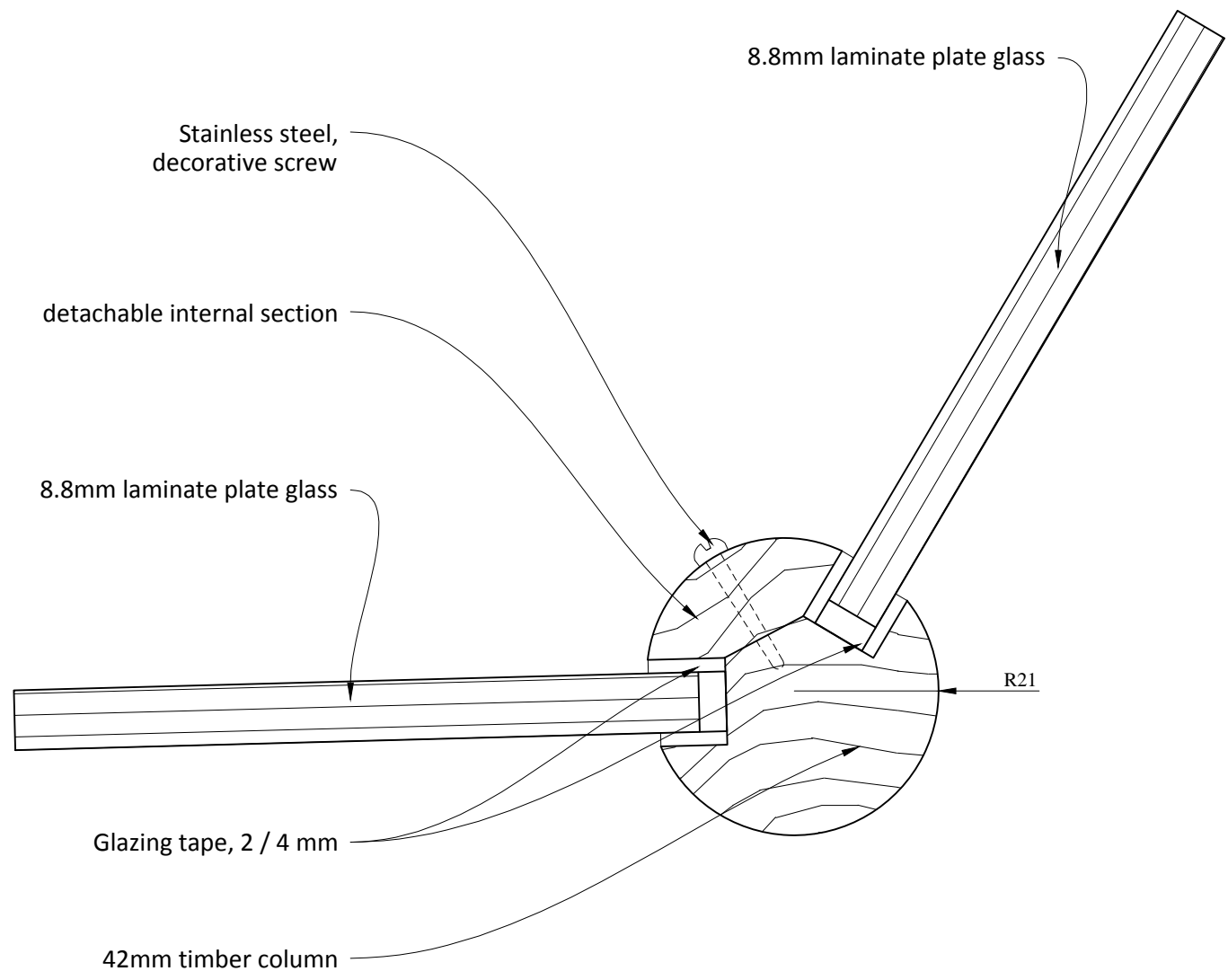

Typical Section - Glazing Column - 1.1 scale

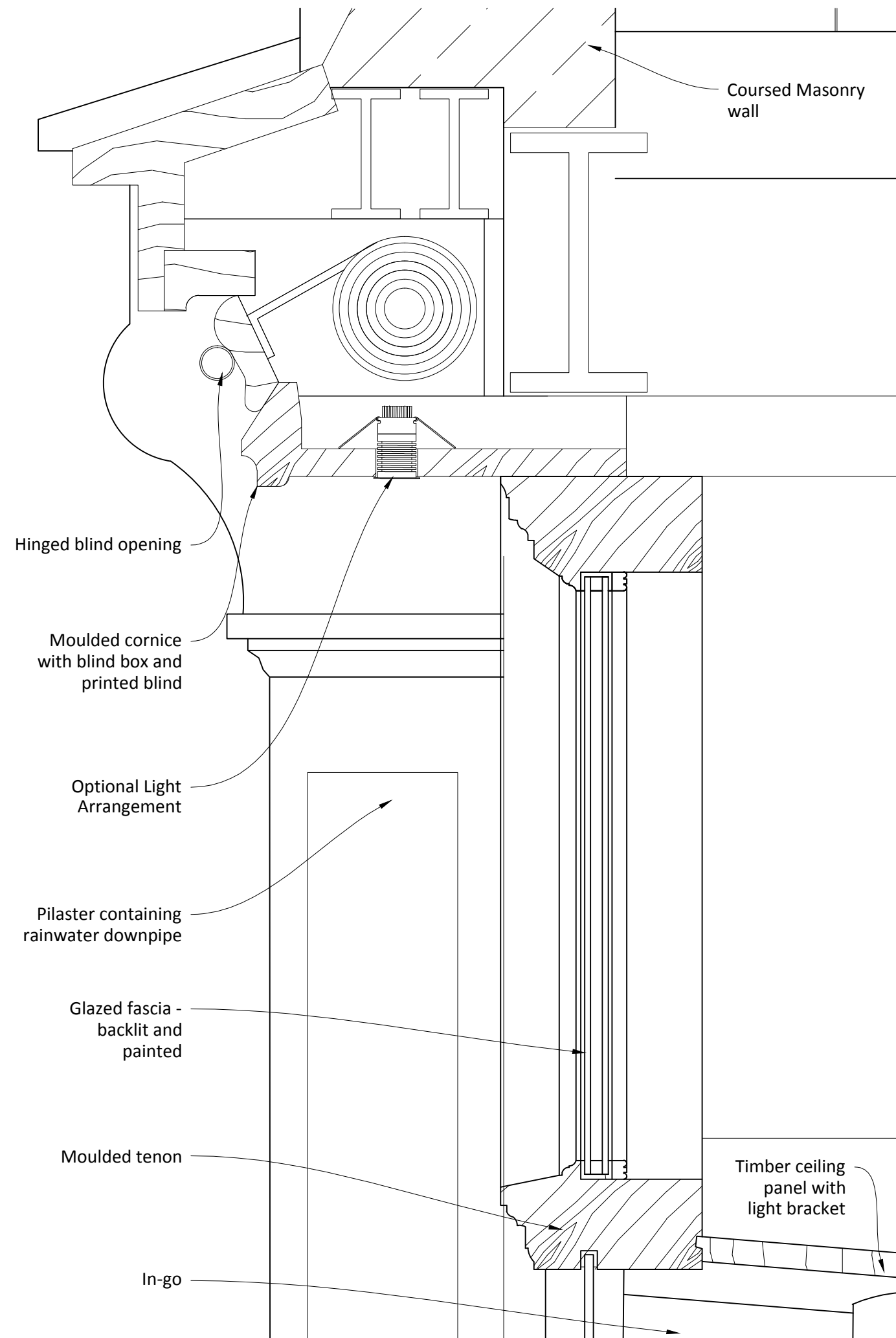

Typical Section Through Shop Fascia - 1.5 scale

**Appendix 2 - General Grant Scheme Summary
Oct 2012**

Total Budget of £355,000 over 4 years			
	Grant Offer Date	Grants Committed/Paid	Outstanding Balance from £200,00
69, 71 & 71a High Street West	July 2008	£19596.88 Paid (£20,198.88 offered)	£180,403.12
23 High Street East	July 2008	£5,735.00	£174,668.12
Glossop Tyre & Battery (25 High St East)	Approved March 2009	£29,195.25	£145,472.87
Kimberley's Bakery 12 High St East	Approved June 2009	£2656.18 Paid (£3,271.54 agreed)	£142,816.69
71-71a High Street West (Bradley's/ Help the Aged)	Approved June 2009	£15,765 Paid (£17,019.30 agreed)	£127,051.69
23 High Street East (supplementary grant)	Approved Sept 2009	£1,712.29 inc VAT paid (£2,332.50 Incl VAT agreed)	£125,339.40
20 Norfolk Street (formerly Blazes)	Approved Sept 2009	£5,776.45 incl VAT	£119,562.95
3,3a High Street West	Approved Sept 2010	£9387	£110,175.95
80-84 High Street West (Pizza Plus etc.)	Approved Sept 2010	£13,602.75 incl VAT	£96,573.20
Harleys Bar	Approved January 2011	£14,000 agreed £13,228 paid	£83,345.20
Victoria Street sketch scheme	Approved October 2010	£4075.00	£79,270.20
Budget Increase		£155,000	£234,270.20
70 High Street West	Approved May 2012	£12,878 incl VAT agreed £10,730.62 exc VAT paid	223,539.58

94 High Street West	Approved May 2012	£6000 incl VAT	£217,539.58
1 Victoria Street – Thomas Cook	Approval subject of this committee	£59,893	£157,646.58
3 Victoria Street – Pizza 4 You	Approval subject of this committee	£79,297	£78,349.58